

POWER QUALITY MEASUREMENTS AND MITIGATION OF DISTURBANCES DUE TO PWM AC DRIVES

P. E. Issouribehere (*), G. A. Barbera (*), F. Issouribehere (*), *Member, IEEE*, and H. G. Mayer (*)

Abstract—Variable speed AC drives are finding their place in all types of industrial and commercial loads. One important application of these drives is in process control, controlling the speed of fans, compressors, pumps and blowers. However, there are many line (source) design parameters frequently overlooked. A pipeline for transporting synthetic crude oil was installed in Argentina and variable frequency drives (VFD) were employed to control the centrifugal pumps, in order to provide flow and pressure control. During the commissioning and start-up program, the IITREE-LAT performed Power Quality measurements and EMC studies in the petroleum process plants. The first part of the paper deals with the problem of common-mode voltages and its mitigation. In the second part of the paper, the preservation of the reference levels for the supply voltage and emission limits for the petroleum plant as a customer is evaluated by measurements of harmonics content in both voltage and current. An LC resonance problem was found and a practical solution was implemented. The fulfillment of power quality limits for both International and Argentinian standards is assessed. Finally, the behavior of the VFD – in terms of PQ indicators – under different load conditions is analyzed in detail.

Index Terms—Harmonics, Total harmonic distortion (THD), variable frequency drives (VFD), power factor, current source inverter (CSI), Electromagnetic Compatibility (EMC), Power Quality (PQ).

I. INTRODUCTION

Four new equidistant pumping stations were located along a 500 km long existing pipeline, with the objective of increasing its transport capacity [1]. In this work, the stations are called A, B, C and D. A simplified scheme presents this situation in Figure 1.

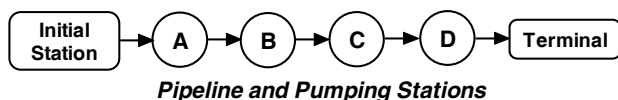

Fig. 1: Transport system including the four pumping stations.

These four identical pumping stations are fed from the 132 kV transmission system. Each of them has two pumps with their respective motors. Both motors have a rated power of 3500 HP and a base speed of 1492 rpm. There is a unique drive in each plant, which is a Pulse Width Modulation (PWM) - Current Source Inverter (CSI)-Fed type. Fed at 6.6 kV, the drive converts the AC voltage into DC and then again

into AC, but this new AC voltage has a variable frequency.

The drives of the four plants control the pumps for keeping a constant level of pressure and transported volume. During the normal process in each plant, at least one of the two pumps, commanded by the drive, works. The other pump can work too, but always with a direct connection to the 6.6 kV busbar. In the case of both pumps running, it is the drive that first commands one of them up to the nominal conditions, and then connects it directly to the supply line. In a second step, the drive turns to command the other pump with a full control.

II. ANOMALIES DETECTED IN THE PLANT

When the plants began operating, some technical problems arose, and they were mainly caused by the operation of the drive. This non-linear device represents the plant main load, since the rest corresponds, basically, to auxiliary services. Essentially, two different issues were detected and, in both cases, their origin was related to the VFD operation.

On the one hand, there is a high frequency pulsing signal produced during the process of converting DC into AC at medium voltage (MV). This occurs during the generation of the variable frequency sine wave. This high frequency signal produces a spurious current which flows through the stray capacitance of the cables and generates common-mode disturbances in voltage waveform (at MV). Due to the fact that such disturbances are common-mode type, they are not present in line-to-line voltages. In addition, as the secondary of the HV/MV transformer is a delta-connection, there is no propagation of this disturbance upstream. Consequently, these disturbances are not “seen” by the Utility. Thus, it does not cause a Customer-Utility controversy. However, these common-mode disturbances caused problems in the internal installation of the plant. There were electromagnetic compatibility (EMC) problems which led to malfunction of digital protections and interference in data networks.

On the other hand, during the process of AC-DC conversion, the supply voltage is rectified at 6.6 kV by using power semiconductor devices. This conversion process generates harmonics in the line current waveform. Depending on the distribution short circuit power, these current harmonics may or not affect the Utility voltage.

According to the current regulation in Argentina, Big Customers are required to evaluate the impact of their plants on the power system. For this reason, it is necessary to measure harmonics at the Point of Common Coupling (PCC).

What follows is a short introduction to the drives employed in each plant before a further analysis of the measurements and the obtained results.

(*)P. E. Issouribehere, G. A. Barbera, F. Issouribehere, and H. G. Mayer are with IITREE-LAT. Facultad de Ingeniería Universidad Nacional de La Plata (UNLP), 48 y 116. La Plata. Argentina (e-mail: iitree@iitree-unlp.org.ar).

III. CURRENT SOURCE INVERTED-FED DRIVES

For medium-voltage (MV) drives, it is convenient to use current source inverter (CSI) technology. The power rating of the PWM current source drives is normally in the range of 1-10 MW and can be increased up to 100 MW with parallel inverters. A detailed description of CSI topologies, operation and control is given in [2].

Figure 2 shows a typical CSI drive using a single-bridge PWM current source rectifier (CSR) as a front end [2]-[4]. Both, rectifier and inverter have an identical topology using symmetrical GCTs. It is possible to operate the drive at 6.6 kV (line-to-line), simply connecting 6 kV-rated voltage GCTs for the given configuration.

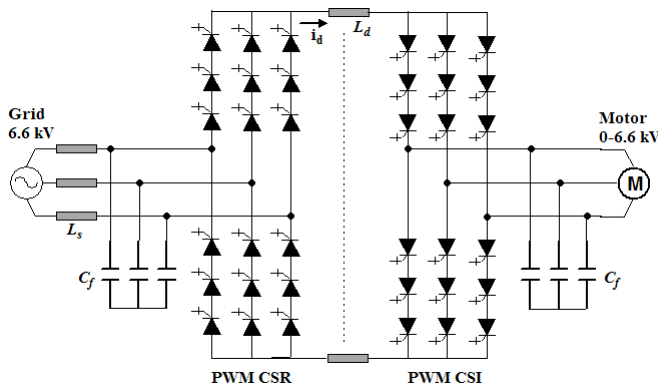

Fig. 2: 6.6 kV PWM CSI drive.

The PWM rectifier can use either the space vector modulation (SVM) or selective harmonic elimination (SHE) schemes. The SHE scheme is preferred due to its superior harmonic performance. With a switching frequency of 350 Hz and a power line frequency of 50 Hz, a maximum of three low-order current harmonics (the 5th, 7th and 11th) can be eliminated. The high order harmonics can be attenuated by a filter capacitor, leading to a very low THD of line current.

The filter capacitor C_f assists the commutation of the GCT devices and filters out harmonic currents. The capacitor size depends on the rectifier switching frequency, LC resonances, required line current THD, and input power factor. This size is normally in the range of 0.3 to 0.6 pu of the CSI drive rated power.

On the dc side of the rectifier, a dc choke L_d is required to smooth the current. The choke usually has a magnetic core with two coils, one connected in the positive dc bus and the other connected in the negative bus. Such an arrangement is used in practice for motor common-mode voltage reduction. To limit the dc link current ripple to an acceptable level (<15%), the size of the choke is normally in the range of 0.5 to 0.8 pu. The dc current i_d can be adjusted by the rectifier delay angle. The delay angle control produces a lagging power factor that compensates the leading current produced by the filter capacitor, resulting in an improved power factor. This can be achieved by using the SHE scheme with a delay angle control and properly selecting the line-side and motor-side filter capacitors. This control scheme features simple design procedure and reduced switching loss, and it is a practical control scheme for the PWM CSI drive.

The PWM inverter uses the SHE scheme at high output

frequencies and the trapezoidal pulse width modulation (TPWM) when the motor operates at low speed. The switching frequency of the inverter is normally below 500 Hz.

The CSI MV drive has the following features [2]:

- **Simple converter topology:** The converter topology is simple and independent of operating voltages. Both converters use symmetrical GCT devices which do not require antiparallel diodes.
- **Non-distorted waveforms:** The motor current and voltage waveforms are close to sinusoidal and do not contain any voltage steps with high dv/dt .
- **High input power factor:** The CSI drive using the PWM rectifier as a front end has a minimum input power factor of 0.98 over a wide speed range.
- **Simple PWM scheme:** The SHE and TPWM schemes are much simpler than those for multilevel voltage source inverters. Only six gate signals are required for the six groups of synchronous switches per converter.
- **Reliable fuseless short circuit protection:** In case of short circuit at the inverter outputs, the rate of rise of the dc current is limited by the dc choke, providing enough time for the drive controller to react. The drive does not need fuses for short circuit or over-current protection.
- **Four-quadrant operation and regenerative braking capability:** The power flow in the CSI drive is bidirectional. No additional components are required for four-quadrant operation and regenerative braking.

The main disadvantages of the CSI are [2]:

- **Limited dynamic performance:** This is mainly due to the use of a dc choke that limits the rate of the dc current changes. Most MV drives are for fans, pumps, and compressors where the high dynamic performance is not very important.
- **Potential LC resonances:** The line-side and motor-side filter capacitors constitute resonant modes with the equivalent short circuit inductance of the power system and motor inductances.

The design specifications of the CSI are given in Table I.

Table I: Design specifications of CSI drive.

Parameter	Description
Nominal input voltage	6.6 kV
Output power rating	200-9000 HP (150-6700 kW)
Output voltage rating	0-6.6 kV
Output frequency	0.2-85 Hz
Input power factor	> 0.98 (with PWM rectifier)
Line Current THD	< 5% (with PWM rectifier)
Motor Type	Induction or synchronous
Control scheme	Direct-field-oriented (vector control)
Rectifier type	PWM GCT
Inverter type	PWM current source
Switches per phase	6@6000 V
Modulation technique	Rectifier: SHE Inverter: SHE and TPWM
GCT Switching frequency	Rectifier < 500 Hz Inverter < 500 Hz

The rectifier and inversion process in the CSI drive generate common-mode voltages. Unless mitigated, the common-mode voltage will appear on the motor, causing premature failure of its windings insulation. An effective solution to the problem can be reached by installing an isolation transformer and grounding the neutral of the inverter filter capacitors.

IV. HIGH-FREQUENCY COMMON-MODE DISTURBANCES

A. Disturbance detection

The first plant to start up was the pumping station B (according to Figure 1) and, as soon as it began working, important common-mode voltages were detected.

By using an isolated, 8-channel waveform-recorder with a 12-bit converter and a sampling rate of 200 ksamples per second, voltages as well as currents in different points of the plant were measured. The objective of these measurements was to verify the presence of high-frequency common-mode disturbances.

A simplified one-wire diagram of the analyzed plant (identical to the other three) is shown in Figure 3. In this graph, the PCC between the Utility and the Customer was remarked.

Recordings were made in points 1 and 2 of the figure; i.e. at 6.6 kV and LV, respectively.

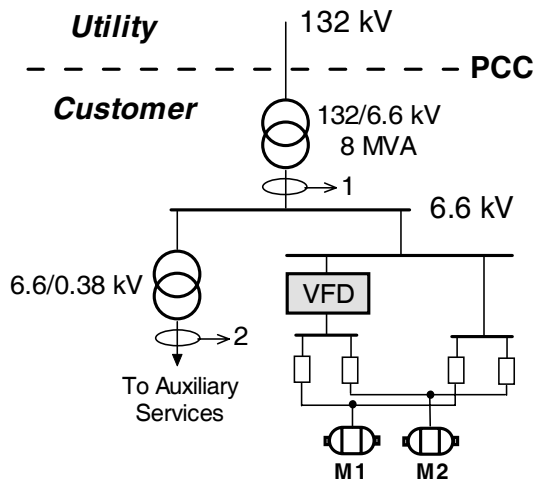

Fig. 3: Simplified one-wire diagram of the plants.

Under no operation of the plant, no disturbance in voltage or in current was observed.

Nevertheless, at the very moment in which the plant began working, high-frequency common-mode disturbances in voltage appeared.

Figure 4 shows the waveform of the three line-to-ground voltages recorded at point 1 of Figure 3. They were captured exactly when the plant started working with the VFD.

The graph shows a very important high frequency disturbance from the beginning of the operation of the plant. It is remarkable that the line-to-ground voltage peak rose from 5.5 kV to 7.3 kV, due to this disturbance.

In order to determine whether this effect corresponded to a common-mode issue, a new recording using higher resolution was taken.

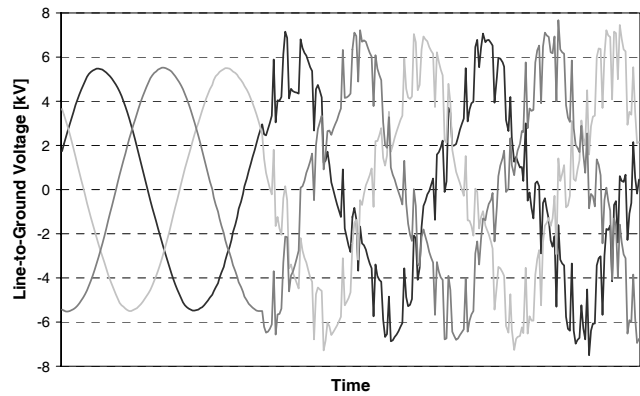

Fig. 4: Waveform of line-to-ground voltages at 6.6 kV during the beginning of the operation.

In Figure 5, enlarged waveforms of the line-to-ground voltages are shown. They correspond to a half-cycle interval (i.e. 10 ms). It can be observed that such a disturbance is clearly a common-mode signal since it is present with the same phase angle in the three phases.

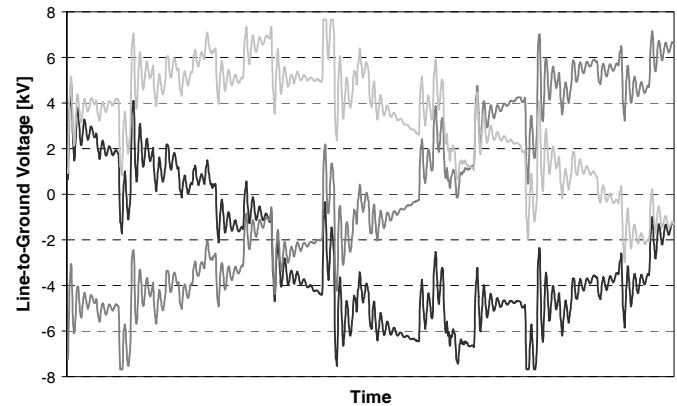

Fig. 5: Enlarged waveforms of line-to-ground voltages.

This waveform has two repeating patterns. The first of them is produced by the square wave related to the inverter sampling rate. The second one could be related to some natural frequency existing in the system. This latter phenomenon has a frequency near 8.3 kHz.

Another way to confirm that the disturbance is of common-mode is to observe the line-to-line voltage under the same operating conditions (this should not be present). The waveform obtained in this case is shown in Figure 6.

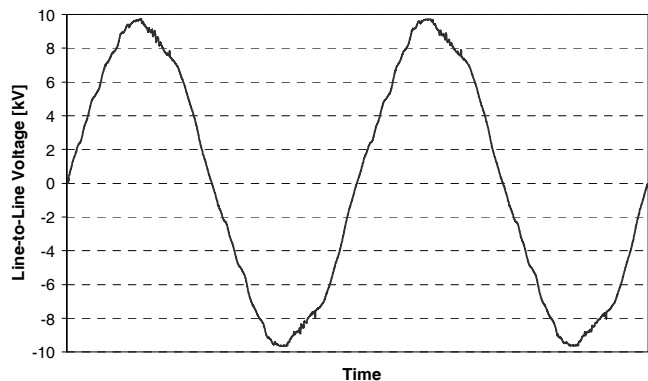

Fig. 6: Waveform of line-to-line voltage at 6.6 kV.

As expected, the waveform did not contain the important disturbances detected in line-to-ground voltages.

In the LV network of the plant some problems were also detected. For this reason, recordings were made at this point, as well. Some of the obtained results are depicted in Figure 7. It is pointed out that none of the captured waveforms presented the disturbances detected in the MV network. Such disturbances were not present because of the delta-wye connection used in the MV/LV transformer (which takes the non-distorted voltage in its delta-connected primary). As a consequence, there was no propagation of the analyzed disturbances on the LV network.

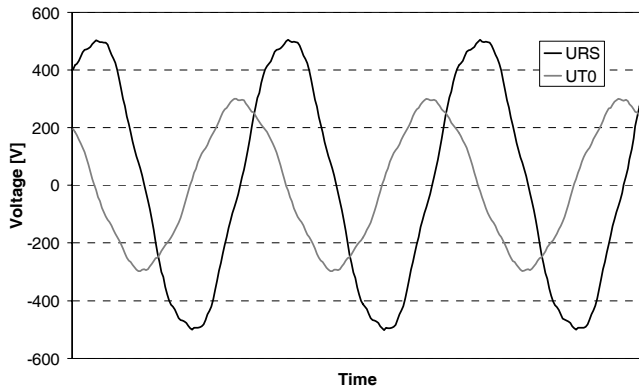

Fig. 7: Line-to-line and line-to-neutral voltages at LV.

Figure 8 illustrates the situation concerning the presence of the common-mode voltage at 6.6 kV.

The switching voltages generated by the drive during the DC-AC conversion produce a current flowing to ground through the cables stray capacitances. These currents return to the source through a loop upstream the VFD.

Such spurious currents seem to return through the center of the wye-connected primary of the HV/MV transformer, and then through its stray capacitance to the drive.

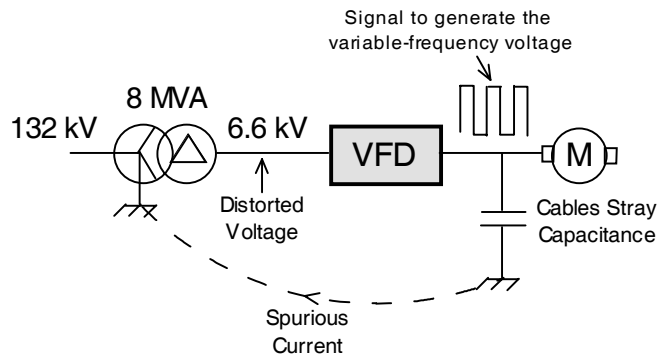

Fig. 8: Common-mode voltage generation.

As it is shown in Figure 8, there is a closed loop for the spurious current. This loop prevents the spurious currents from flowing beyond the transformer and, therefore, they do not appear at PCC.

B. Disturbance mitigation

The insertion of a filter in the drive input in order to decrease the common-mode impedance at the disturbance frequency is the usual solution for this kind of EMC problems. It is also recommendable to shield the cables that

feed the motor, so as to prevent electronic equipment nearby from being affected by the spurious currents.

A simplified scheme for the mentioned solution is shown in Figure 9.

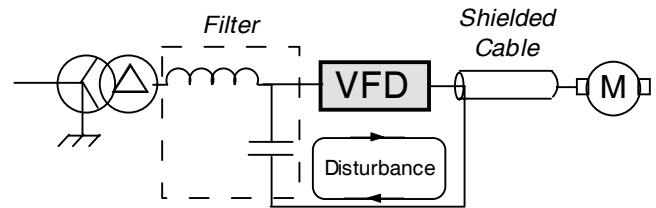

Fig. 9: Solution to mitigate the common-mode voltage.

In this way, the high-frequency disturbances are restricted to the loop cable-filter-drive and, therefore, would not affect line-to-ground voltages.

Another solution, instead of using a filter, consists in avoiding connecting measuring equipment, protections and transducers respect to ground, but connecting them to line-to-line voltages. This connection appears to be more appropriate for a network with isolated neutral point. Line-to-line voltages do not contain the common-mode disturbances produced by the drive.

V. HARMONICS

A. Plant evaluation

Apart from the phenomenon previously dealt with, harmonics of the 50 Hz power frequency are also produced by the VFD during the process of AC-DC conversion.

In this case, disturbances appear upstream the HV/MV transformer. This issue differs from the phenomenon discussed in the previous paragraph since it has direct impact on the Utility grid and, for this reason, it must be carefully evaluated.

Both, Utility and customer agreed to use the standard IEEE 519-1992 [5] as a reference in order to assess the harmonic content emitted by the customer.

Prior to the official start up of the plants, preliminary harmonic measurements were made (official measurements are required to permit the plants to operate normally).

In Figure 10, it is shown the active power of the plant during the measuring period. Added to this, the different working states of the plant were indicated. Between two consecutive steady states of operation, a transient appears due to the inertia existing in the process.

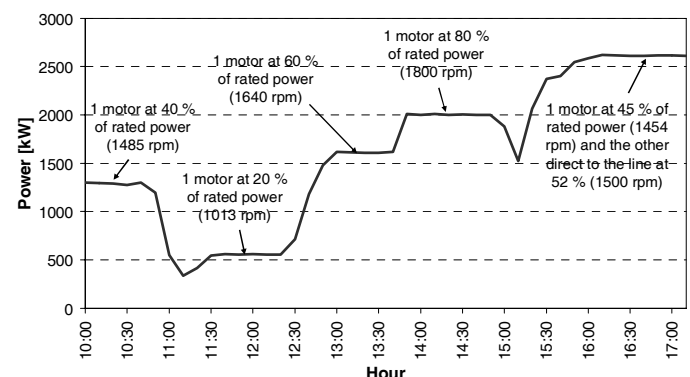

Fig. 10: Different operating states of the plant.

B. Detection of even harmonics

Firstly, harmonics of the line current were analyzed. In the case of one motor running at 80% of its rated power and at 1800 rpm, it was observed a sharp increase of the even harmonics produced by the VFD, which are very unlikely to appear in such industrial plants. The 2nd and the 4th harmonics presented the highest magnitudes of all even harmonics. Figure 11 shows the profile of both harmonics. The 8th, 14th and 16th harmonics also showed important rises in their magnitude. The harmonic emission greatly exceeded the established limits [5].

After looking into this issue, the drive manufacturer noticed that at over speed conditions (rated value 1492 rpm) the drive became unstable. Speeds over base speed are achieved by going into a flux weakening condition. Apparently, due to problems in the control algorithm, the motor flux was not reduced as much as it should have been, which resulted in a malfunction of the VFD.

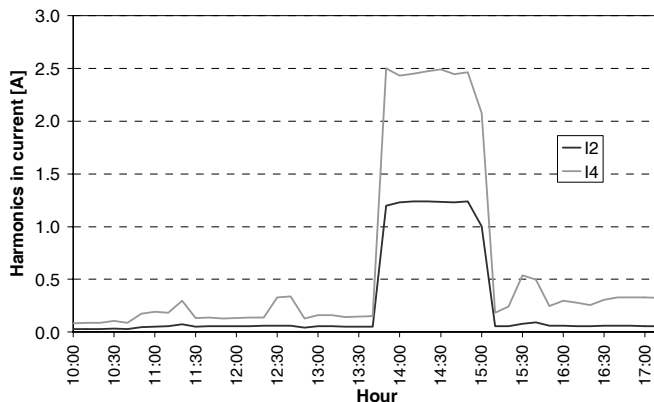

Fig. 11: Trend of 2nd and 4th harmonic current.

To correct this, the drive control firmware was upgraded. After the firmware was changed, the instability problem disappeared. This was confirmed by new measurements showing that the magnitude of the even harmonics were now within the standard limits for all working conditions.

C. Problem with the 5th harmonic

Once the issue concerning even harmonics was solved, an important flow of 5th harmonic current was detected. Surprisingly, this harmonic current was present even with the drive connected to the line, but not operating.

Figure 12 shows the waveform of line-to-ground voltage and current at 6.6 kV under this condition. Voltage does not present noticeable disturbances, but current presents high 5th harmonic content.

After looking into the case, it was noticed that the drive included a filter capacitor of 1200 kvar per phase at the input. The purpose of this filter is to prevent the disturbances generated in the PWM process from propagating on the grid. In figure 12 it can be observed that current leads voltage by 90 degrees, this is because the only load connected to the system at this moment was the filter capacitor C_f .

Due to the existence of the filter capacitor, it was necessary to study a possible resonance between C_f and the line reactance L_s (see Figure 2). L_s represents the total inductance of the grid, the HV/MV transformer and the rectifier.

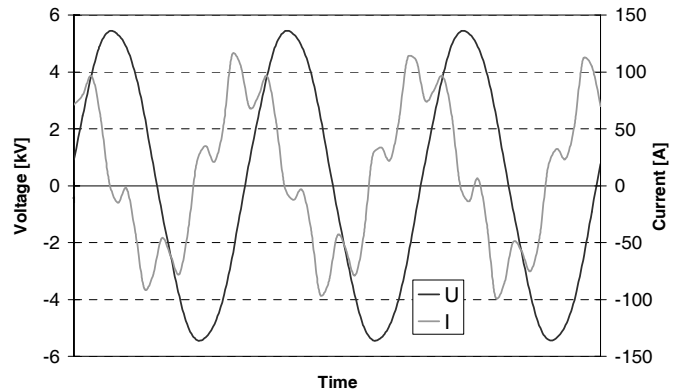

Fig. 12: Waveform of voltage and current with the VFD connected but not operating.

According to the information provided by the transformer manufacturer, the resonant frequency between the network and the filter capacitor can be estimated:

$$S_{cc} = \frac{S_r}{Z_{cc} (\%)} = \frac{8 \times 10^6}{0.092} = 87 \text{ MVA} \quad (1)$$

Thus the resonant frequency is calculated as:

$$f_r = f_0 \sqrt{\frac{S_{cc}}{Q}} \quad (2)$$

In the case of a capacitive filter of $Q = 3600$ Kvar, the resonant frequency is $f_r = 245$ Hz.

Therefore, the load presented an extremely low value of impedance at the 5th harmonic. As a consequence, although the 5th harmonic of the Utility voltage was not so important (see voltage waveform in Figure 12), the 5th harmonic current taken by the load was high (see current waveform).

The manufacturer must have designed the filter so as to present a resonance at a frequency between the 5th and the 6th harmonic, considering infinite short-circuit power. But in a real network, the resonant frequency is shifted towards the 5th harmonic.

In order to suppress the resonance at 5th harmonic, it was necessary to shift this resonant frequency towards a different value of the spectrum. Since the only variable that was possible to change was the capacitance, its value was reduced from the original 1200 kvar to 800 kvar (the capacitor bank consisted of three 400-kvar modules).

In Figure 13 the system transfer function for both values of capacitance is depicted. As it was estimated above, with 1200 kvar, the resonance occurs at approximately the 5th harmonic. With the new value of capacitance, the resonance occurs at approximately 300 Hz, i.e. at 6th harmonic.

The 6th harmonic voltage is normally low (at least much lower than the 5th harmonic). Therefore, even though the reactance presented by the load at the 6th harmonic is low, the current harmonic content will be much lower with the new value of capacitance.

This change of capacitance was implemented in the four plants. After that, it was proved by field measurements that the 5th harmonic current decreased dramatically in all of them, while the 6th harmonic current slightly increased.

As a conclusion, the harmonic emission was lower with this change.

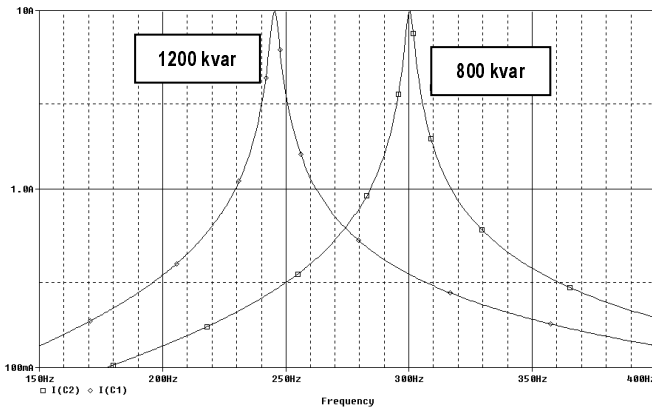

Fig. 13: System frequency responses for the two values of capacitance: 1200 and 800 kvar capacitors.

D. Impact of the Plants on the Power System

Once all issues concerning harmonic emission were solved, the next step was to measure the voltage harmonics at PCC and compare them to those established in the IEEE standard 519-1992.

These measurements showed a 5th harmonic voltage over the established limit during some periods of time. Whereas the maximum allowable value for the 5th harmonic is 1.5 % – for this voltage system – values as high as 2.5 % were recorded. The profile obtained is shown in Figure 14.

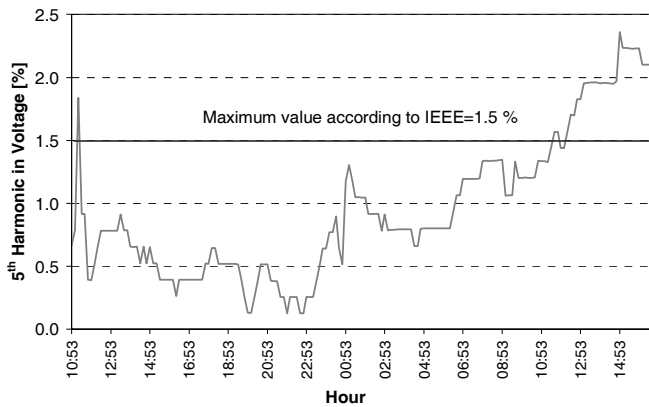

Fig. 14: Trend of 5th harmonic voltage.

The rest of the harmonics remained below the established levels.

Thus, it was necessary to determine the origin of this 5th harmonic in voltage waveform. The 5th harmonic had previously been found in current, but this issue had already been solved (see C). Therefore, in order to determine whether this disturbance was generated by another load connected to the grid, a new measurement was performed.

A harmonic recorder was connected to the PCC for several days. During this period of time the plant was either pumping or completely out of service.

In Figure 15, the values measured of 5th harmonic voltage as well as the power taken by the plant are shown. In solid line, the maximum allowable value for the 5th harmonic voltage is also included.

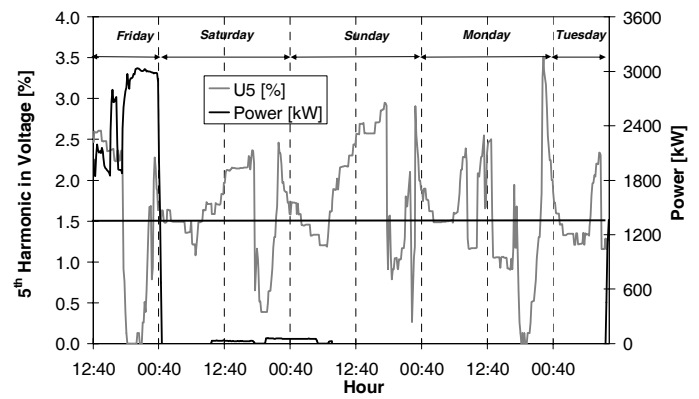

Fig. 15: 5th harmonic voltage and power taken by the plant.

According to the profile obtained for the power, it is observed that the plant pumped only during the first day of the measuring period. After the first day, only the auxiliary services were fed.

As it can be observed from the trend, values of 5th harmonic over the limit were recorded under both conditions, i.e. with the plant working and with this out of service. In fact, the highest level of 5th harmonic voltage was recorded when the plant was not operating. Consequently, it can be affirmed that this disturbance was not produced by the plant, but by another load connected to the Utility grid.

As a conclusion, it can be stated that the plant does not produce any impact on the grid.

VI. VFD BEHAVIOR UNDER DIFFERENT LOAD CONDITIONS

In general, drives behavior as regards harmonic emission and power factor depends heavily on the condition they are operating [6].

In this particular case, the behavior of the plant was analyzed in detail. In order to achieve this, a PQ monitor was installed at 6.6 kV busbar for a week, while the plant worked normally. As it was mentioned at the beginning of this work, it is possible to differentiate three different ways of operation, which vary according to the product that is being transported:

1. **One motor controlled by the VFD**, which is the least favorable situation concerning harmonic emission – unless the drive operates at full load, full speed.

2. **One motor connected to the line**, this condition only takes place when for some reason the drive stops working, and then it is not likely to occur regularly. Obviously, in this case the line current is completely free of harmonics.

3. **One motor controlled by the drive and the other connected directly to the line voltage**. In this case the emission is lower than in the first one, as the current waveform basically consists of an addition of two different terms, one containing harmonics – due to the motor controlled by the drive – and the other free of harmonics, due to the motor fed directly from the line.

Several analysis were carried out, in which different PQ parameters were correlated with the state of the plant.

A. Harmonic emission vs. state of the plant

In Figure 16 the profiles of both, the power taken by the plant and the THD of the line current are shown.

Throughout the measuring period the plant worked under the three conditions above described. It is remarked that the plant worked with only one motor directly fed from the line voltage during short periods of time which took place during 2nd and 3rd May. This explains why the THD I [%] decreased dramatically, while the power remained practically the same.

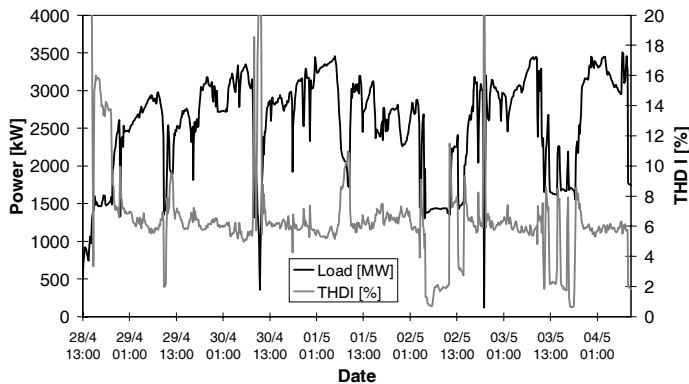

Fig. 16: Profile of THD I [%] and power.

In Figure 17 the correlation between these two variables is depicted. With different symbols, the three operating conditions were represented. The load was represented as a percentage of the rated power of the whole plant, which consists of the two pumps plus the auxiliary services.

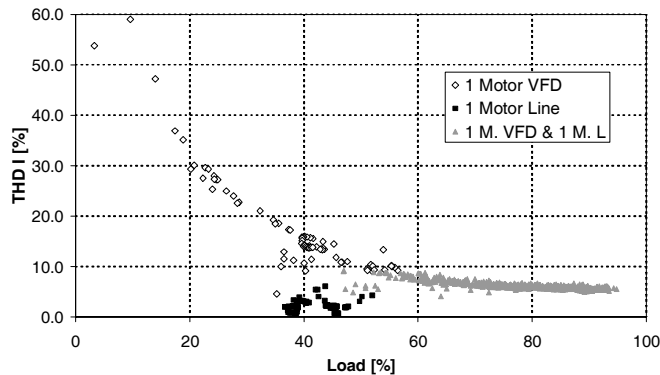

Fig. 17: Load vs. THD I [%].

The recorded values for the condition with only one motor connected to the line correspond to the black squares.

The load fluctuated around the 50 per cent of maximum value and – as expected – the harmonic emission was always below 8 %.

When it comes to the condition with both pumps working, the recorded values are those represented by grey triangles. Most THD I [%] values remained below 10 %, regardless of the load value. The higher values of load, the lower levels of harmonic emission.

Finally, those periods with only one motor controlled by the drive were represented by rhombuses. Under this condition, the emitted levels depended heavily on the load. With levels of load near the rated value of the drive, the emitted levels were as low as 10 %. Nevertheless, for those levels of load below 60 % of the rated value of the drive – about 40 % of the rated power of the plant – the levels of THD I [%] recorded were rather high.

B. Power Factor vs. state of the plant

In Figure 18 the correlation between state of the plant and power factor is shown. The load was represented in the axis of abscissas in the same way as in Figure 17.

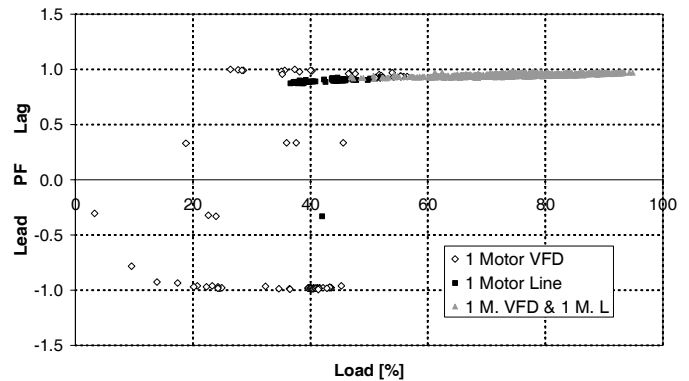

Fig. 18: Load vs. Power Factor.

Under the condition with one motor controlled by the drive, the PF value depended again on the load. This was either lagging or leading and most of the time really close to one.

With one motor connected to the line, a lagging PF around 0.8 was observed. This value is due to the fact that at this moment the only important load in the installation was the motor, with no compensation.

Finally, with both pumps working, the PF was always lagging and over 0.9.

C. I_1 and I_{rms} vs. load

The last analysis carried out consisted in obtaining the correlation between load and current. In Figure 19, the correlation is shown considering both currents, fundamental and rms. The three different conditions of working were not differentiated in this graph.

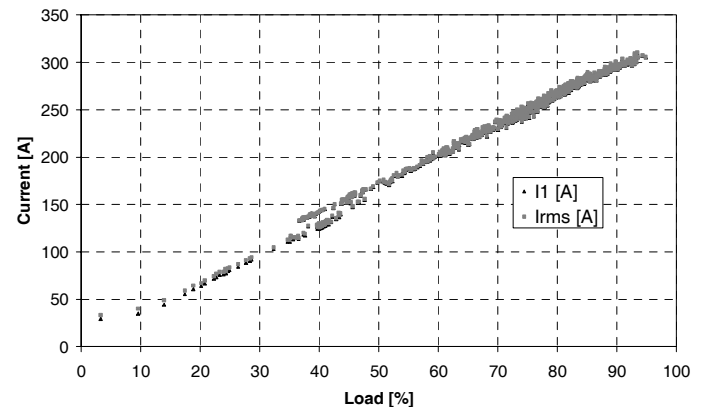

Fig. 19: Load vs. I_1 [%] and I_{rms} [%].

For high values of load, the harmonic emission is not that high. Consequently, both currents were similar. On the other hand, since for light load the harmonic emission is higher, a difference between both lines was observed. Nevertheless, such a difference was not as important as expected.

Since THD I [%] reached values as high as 54 % for light load conditions, a major difference between the two currents was expected under this condition. However, it was then found that the mathematical relationship between both currents is the following:

$$\frac{I_{rms} [A]}{I_1 [A]} = \sqrt{1 + \left[\frac{THD I [\%]}{100} \right]^2} \quad (3)$$

The THD I [pu] is squared and – after adding 1 – a root square is applied. Consequently, even though the THD I was as high as 54 %, the relationship between the two currents turned out to be only 14 %.

To sum up, all the results obtained in the analyses that were carried out in this section were consistent with drives behavior in general.

VII. FINAL MEASUREMENTS

Once all the discussed problems were solved, it was necessary to perform an official one-week measurement in each site so that the four plants would be permitted to operate regularly.

THD of voltage as well as harmonics up to the 40th were recorded. The results obtained are shown in Figure 20. Each harmonic voltage was represented by its P95 value.

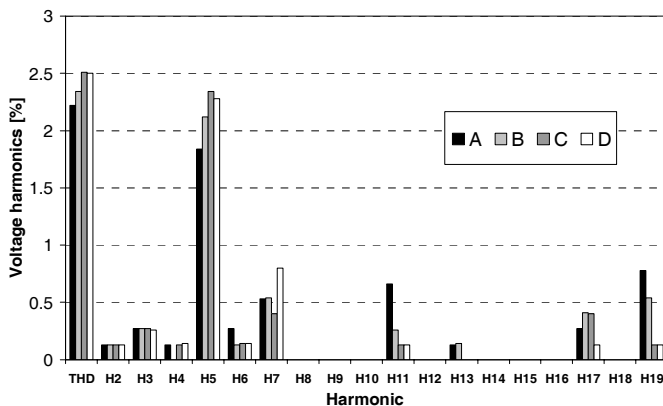

Fig. 20: Harmonics recorded in the four plants.

It can be observed from the graph that the harmonic levels obtained in the four plants were similar. Moreover, the harmonic that showed the highest magnitude in all the sites was the 5th.

In general, the harmonic levels were lower than those established in IEEE 519-1992. The only harmonic whose P95 was over the limit was the 5th. However, as it was concluded in the previous section such a harmonic was not caused by the plants, but by another load connected to the power system.

Finally, since it was proved by measurements that the plants do not cause any impact on the grid, the four plants were enabled to operate regularly.

VIII. CONCLUSIONS

- When a new Big Customer including non-linear loads in its installation connects to the grid, the Utility must require the Customer to evaluate the impact of the plant on the power system.
- In addition, the Customer should carry out a previous study in order to determine all the inconveniences that are likely to arise within its installation.
- Common-mode disturbances were detected in the plants. Such disturbances did not affect the Utility voltage.
- When harmonics are detected at PCC it is worth

determining where they are generated.

- A high 5th harmonic voltage was measured at PCC. Nevertheless, it was proved that such dominant harmonic was not generated by the Customer.
- All the measurements as well as the studies performed showed that the plants caused no impact on the grid.
- The VFD behavior concerning harmonic emission and PF – under different operating conditions – was as expected: the best performance occurred at full load, full speed.

IX. REFERENCES

- [1] F. Dewinter, B. Kedrosky, “The application of a 3500-hp Variable Frequency Drive for Pipeline Pump Control”. *IEEE Transactions on Industry Applications*. Vol. 25 N° 6. Nov./Dec. 1989.
- [2] Bin Wu, “High-Power Converters and AC Drives”. *New Jersey: John Wiley and Sons, 2006. ISBN: 978-0-471-73171-9.*
- [3] Bimal Bose, “Modern Power Electronics and AC Drives”. *Prentice Hall PTR, 2002. ISBN: 0-13-016743-6.*
- [4] Mohan, Undeland, Robbins, “Power Electronics”. *2nd Edition. John Wiley and Sons, 1995. ISBN: 0-471-58408-8.*
- [5] *IEEE Recommended Practices and Requirements for Harmonics Control in Electrical power Systems. IEEE Std. 519-1992.*
- [6] Frederick Hoadley, “Comparison of methods for the mitigation of line disturbances due to PWM AC drives”. *Pulp and Paper Industry Technical Conference, 2007, Conference Record of Annual, pp. 78-92.*

X. BIOGRAPHIES



Pedro Eduardo Issouribehere received the Engineer degree from La Plata National University, Buenos Aires, Argentina, in 1971. He is a Full Professor and a researcher of IITREE-LAT – a Research Institute and High Voltage Laboratory - of La Plata National University (UNLP), Buenos Aires, Argentina.

He has worked for UNLP since 1970 as a specialist in electronic applications to electrical laboratories and EMC measurements in Power Electric Systems.

As responsible for IITREE Technical Assistance Area, he has developed control methods of Power Quality and Electromagnetic Environmental Impact and their application in Argentinian and South American Electrical Markets.

He is Observer Member of CIGRÉ C4 National Committee.



Gustavo A. Barbera received the Engineer degree from La Plata National University, Buenos Aires, Argentina, in 1996. He has worked as a researcher for IITREE-LAT of UNLP since 1996.

He carries out and processes power quality measurements, especially regarding voltage level and disturbance studies.

He is a professor at the Electrical and Electronic Engineering Department, La Plata National University.



Fernando Issouribehere received the Engineer degree from La Plata National University, Buenos Aires, Argentina, in 1999 and a Master in Electrical Engineering Degree in 2006. He has worked as a researcher for IITREE-LAT since 2000.

His research interests include power electronics, power quality, and power systems operation and control.

He is an assistant professor at the Electrical and Electronic Engineering Department, La Plata National University, Argentina.



Hugo G. Mayer received the Engineer degree from La Plata National University, Buenos Aires, Argentina, in 2006. He has worked as a researcher for IITREE-LAT of UNLP since 2007.

He carries out and processes power quality and EMC measurements, especially regarding voltage level and disturbance studies.

He is an assistant professor at the Electrical and Electronic Engineering Department, La Plata National University, Argentina.