

Fast Transients in the Operation of an Induction Motor with Vacuum Switches.

R. Bianchi Lastra
 IITREE-LAT

Fac. de Ingeniería-UNLP
 (1900) La Plata, Argentina
 rbianchi@ing.unlp.edu.ar

M. Barbieri
 IITREE-LAT

Fac. de Ingeniería-UNLP
 (1900) La Plata, Argentina
 barbieri@ing.unlp.edu.ar

Abstract - Generally in industrial plants, overvoltages of impulse type are not considered, hence the impulse test of the equipment is not specified. This paper shows one of these cases, but high and fast voltage transients can arise in a 2.3 kV system, when the starting autotransformer of a 1750HP motor is operated through a vacuum switch, and can explain the power failure of autotransformer.

A model was built in the ATP for simulating switching operations that are not easy to be tested in the real system or difficult to record such as multiple re-ignitions of the arc in the circuit breaker. MODELS was used to build the control logic that simulates the multiple re-ignitions of the arc.

Keywords: Vacuum Circuit Breakers, Transients overvoltages, Re-ignitions, EMTP/ATP, MODELS.

I. INTRODUCTION

In an industrial plant, a severe failure occurred when a motor was operated through a starting transformer, and consequently the bus transformer and the starting transformer were destroyed.

The purpose of this paper is to show the results of the study made to determine the transient behavior that occurs during the motor operation, and tries to explain the power failure of the transformers.

It is worth mentioning that initially the installation had airblast circuit breaker, and in an upgrade of the system, this circuit breaker was replaced by vacuum switches.

Also it must be noted that as the industrial plants are generally considered to be electrically far away from transients generated for the lightning activity, then it is normal not to specify impulse test to the equipment.

In the common case, when a motor is operated directly by the circuit breaker, the occurrence of multiple reignitions when breaking the starting current can produce high frequency overvoltages, that stress the inter turn insulation of the motor.

When a starting transformer is used to operate the motor, then it is the starting transformer, which must withstand this solicitation. It is easy for the transformer manufacturer to obtain a good insulation of the first coils to withstand this stress, but in the case of industrial equipment of low voltage, this requirement is not always taken into account.

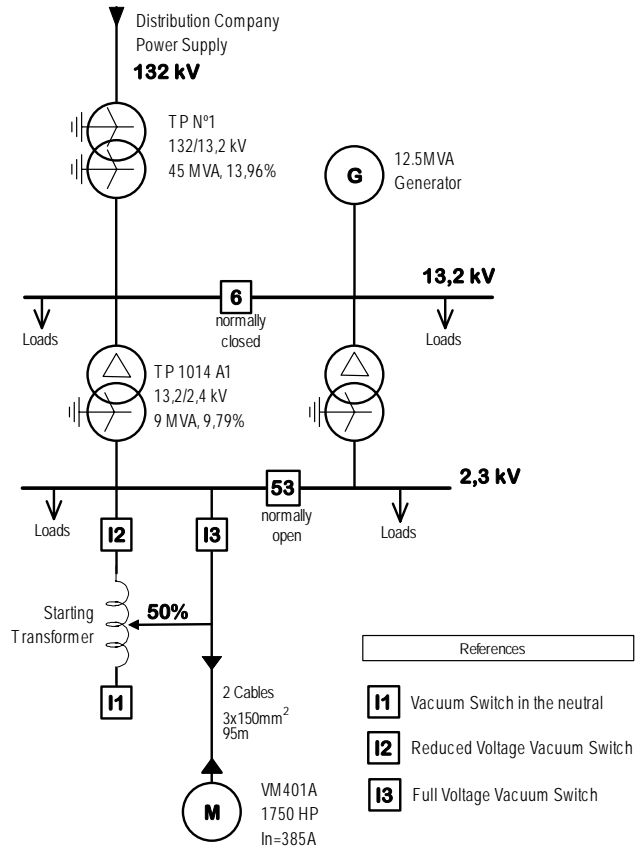

Fig. 1. Single-wire of the network to simulate.

II. DESCRIPTION OF THE NETWORK.

In Fig. 1, it is shown a single-wire of the network to be simulated. The Distribution Company supplies energy through a 45 MVA transformer of 132/13.2 kV, but also the industrial plant has its own generator of 12.5 MVA, connected to the 13.2 kV bus bar too.

Practically, induction motors form all the loads of the plant. Only the motor under study has a starting transformer.

This motor is connected to the 2.3 kV through a cable of 95 m length, and the failed transformers are the TP1014A1 and the starting transformer showed in the figure, both failures were on the 2.3 kV coil. There is no cable between both transformers, the connection is through bus bars.

The switch I2 is the vacuum switch under study. I1 and I3 are also vacuum switches that complete the installation.

III. MODEL OF THE SYSTEM.

The main difficulty to build the model of the system was the lack of certain important parameters of the elements of the network. For example, the behavior of the arc and the recovery dielectric strength between contacts of the circuit breaker are unknown; neither the stray capacitance of the transformers nor the necessary information for building a detailed model for high frequency transients.

That situation forces to use simple models, and to do some simplifications, taking into account the sensitivity of the transients with respect to the parameters of the network. Here was very important some previous experiences of our Institute in measuring and simulation of high frequencies transients [1], [2].

A description of the used model follows.

IV. THE EQUIVALENT CIRCUIT.

The main objective is to simulate the fast transients due to possible reignitions of the arc in the vacuum switch, therefore a good representation of the elements around the switch and the behavior of the switch itself is necessary.. The representation of the other elements of the system, like the power supply and the motor, are necessary though to obtain a good representation of the steady state previous to the transients, and are 'low frequencies models'

A. Vacuum switch

As the parameters that describe the behavior of the arc in the vacuum switch are not known, we did not use a model in which it is simulated. We used a simple switch model (type 13), which is controlled by means of a logic imposed in MODELS, simulating the multiple re-ignitions of the arc in it.

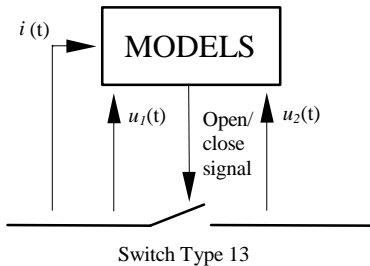

Fig. 2. Signals between MODELS and ATP

This model takes into account the following qualities:

- The characteristic recovery dielectric strength between contacts when opening.
- The ability of the circuit breaker to chop the current before its natural zero ("Chopping Current").
- The rate of decay (slope) of the current prior to current zero, that the switch is able to interrupt. This value is function of the time after contact separation, and may be positive or negative. However, the digital model considers this value as constant.

The control logic implemented in MODELS, that allows simulations of multiple re-ignitions (scheme in Fig. 2), is the following:

- After mechanic separation of the contacts of the circuit breaker, it is considered that the dielectric strength between them grows up linearly, with a definite slope. This straight rise defines the transient recovery voltage withstood between contacts for each instant after the current interruption.
- The voltage between contacts in each instant, $u_1(t)-u_2(t)$ in Fig. 2, is compared with the withstood voltage (defined by the above mentioned straight rise) and in case it is surpassed, a closing signal is given to the switch, so a re-ignition of the arc is simulated.

If the re-ignition occurs, then two conditions should be fulfilled for the switch to interrupt the current again:

- a) The slope of the current through zero must be under a definite value, and
- b) The instantaneous value must be smaller than that which the circuit breaker can chop ("Chopping current").

Only in the case where both conditions are met, an opening signal for the switch is produced.

The preceding logic is repeated for each time step, and in this way it is possible to simulate the multiple re-ignitions phenomena.

For the present study, the following values are used:

- Slope of recovery strength = 20 kV/ms
- Chopping current = 10 A
- Slope of the current, when passing through zero that the switch is able to interrupt = 150 A/ μ s.

These values were taken from [3], and from the experience [1], [2].

B. Power Source

The generator was represented like an ideal generator with impedance of 20%.

The power supply is modeled with zero and positive equivalent impedance, obtained from the mono and three-phase short circuit power values, that are 1800 and 2000 MVA respectively.

C. Transformers.

The models for the transformers can be divided in two parts:

- The simple TRANSFORMER model of the ATP, to simulate the steady state previous to the switching of the vacuum switch.
- Capacitance to ground to simulate the transformers for high frequency transients.

The stray capacitance value of the starting transformer is not known, so it was used a value of 2 nF for the 2.3 kV coils, that is obtained from [4] and [5].

As regards the stray capacitance of the TP1014A1 transformer, we can adopt a similar value. However, it is noted that at 2.3 kV bus bar other loads are connected, and it must also be taken into account the stray capacitance of the bus bar. So, the total stray capacitance on the source side of the vacuum switch will be higher than the corresponding to the starting transformer.

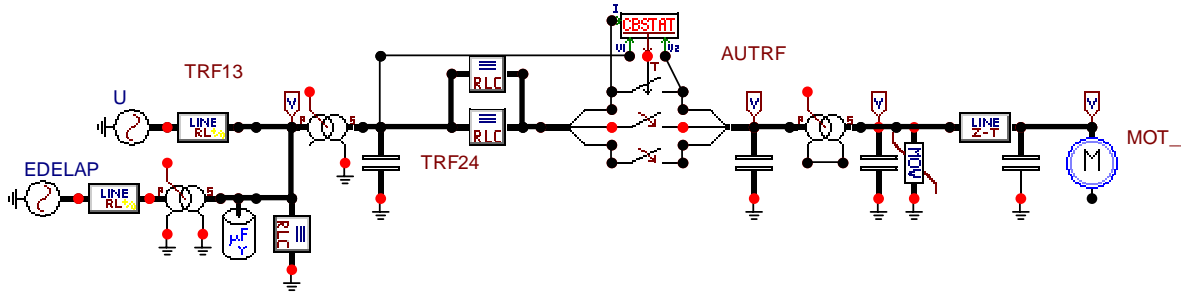

Fig. 2 Complete model of the system builder with the ATPDraw

D. Cables and busbars.

A model with distributed parameters was used to represent the cables (two in parallel) that connect the motor to the starting transformer. The used values were:

$$\begin{aligned} Z_c &= 50 \Omega \\ v &= 180 \text{ m}/\mu\text{s} \\ \text{Length} &= 95 \text{ m} \end{aligned}$$

For the representation of the bars that connect the transformers to the vacuum switch, it was adopted a value of $20\mu\text{H}$.

E. Equivalent circuit of the motor.

The equivalent model of the motor is an impedance $R+jX$, which represents the motor in the starting state conditions. The parameters of the motor used to obtain this equivalent are:

$$\begin{aligned} U_n &= 2,3 \text{ kV} \\ P_n &= 1750 \text{ HP} \\ I_n &= 385 \text{ A} \\ I_{arr}/I_n &= 6 \\ \text{Cos } \varphi_{arr} &= 0,15 \end{aligned}$$

After this preliminary calculation, the equivalent circuit for the chosen typical case was modelled with the ATPDraw (Fig. 2).

V. TRANSIENT SIMULATIONS

The probabilities of occurrence of reignitions are related with the slope of the recovery voltage strength between contacts and with the transient recovery voltage (TRV). The higher the slope the less probability of reignitions and inversely, for the higher TRV, the higher probability.

It is known that the interruption of the starting current of a motor is one maneuver when the reignitions have more possibilities to occur. That is why in this situation there is not emf in the motor, and then the TRV between contacts of the circuit breaker is worst than in other cases.

In addition, since the TRV is the composition of the voltage at both terminals of the switch, it will depend on the circuit at both sides, principally with the characteristic

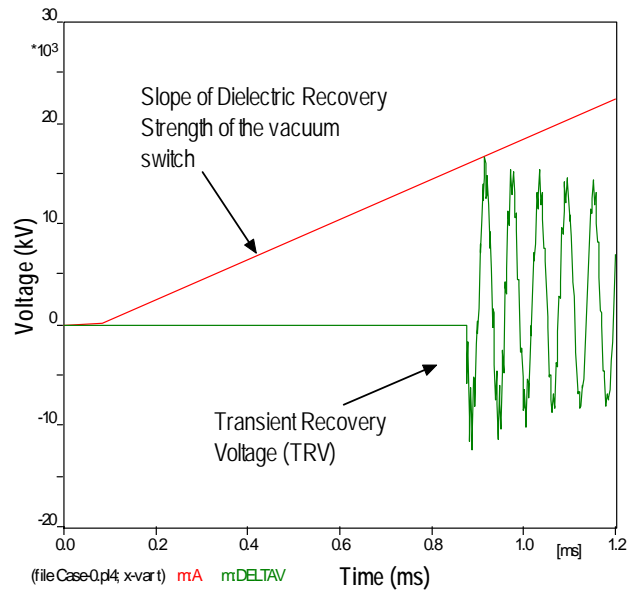

Fig.3 Slope of recovery dielectric strength and TRV between contacts.

impedance of the load, and with the chopping current capacity of the switch.

The Fig. 3 shows the slope of the recovery voltage strength considered in this study and the TRV between contacts of the vacuum switch when the starting current of the motor is interrupted, obtained with the assumed values of the parameters and the digital model.

Fig. 3 show that the reignition will occur if the arc time, i.e., the time between mechanical separations of the contacts and the instant of current chopping, is less than 0.8 ms approximately.

However, it is to be noted that we adopt estimated values for the stray capacitance for the equipment on the load side of the switch. Then their characteristic impedance will be approximated too. Also it must be considered the random nature of the chopping current.

Both considerations have the effect of modifying the waveform and crest value of the TRV, and then the arc time to get reignitions can be higher or lower than the previous value.

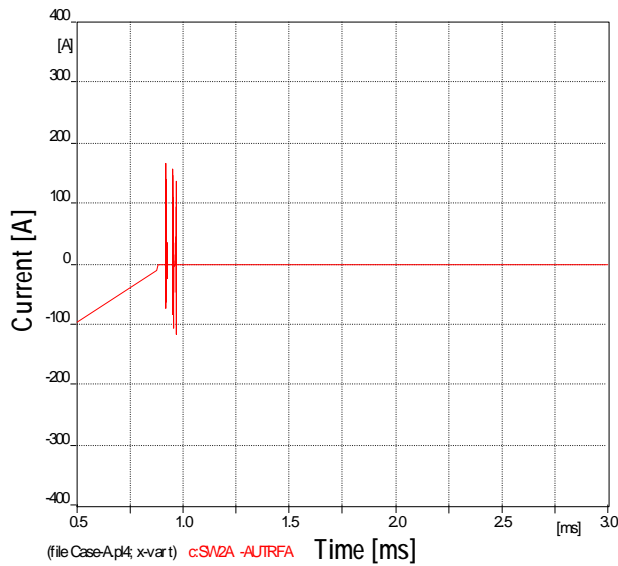
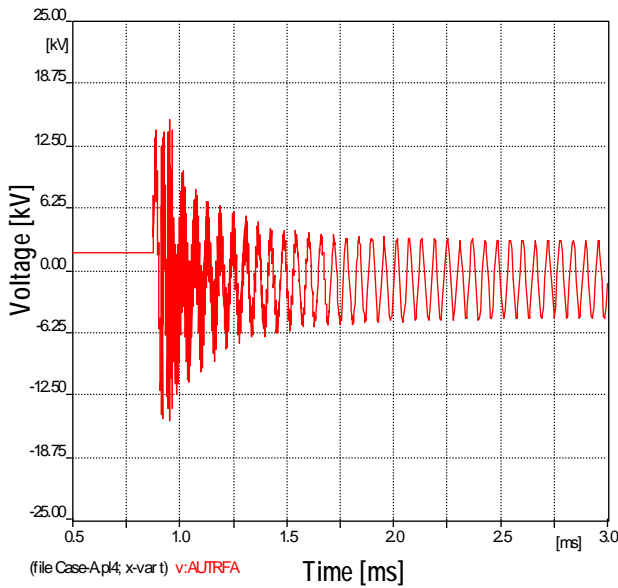

Fig. 4. a) Voltage at starting transformer, b) current through vacuum switch. Arc time = 0.8 ms

To get an estimation of the transients that can occur in this system, we make the simulations of reignitions for two extreme values of the arc time.

In case a), the arc time is approximately 0.8 ms, and in Fig. 4, it is shown the resulted waveform of the voltage to ground, at starting transformer terminals, and the current through the switch.

In case b), the arc time is approximately 0.25 ms, and in this case the waveforms are shown in Fig. 5.

Both cases show the multiple reignition phenomena.

It is observed in case a), that after a few reignitions, the current is interrupted and the voltage goes to zero through a low frequency oscillation

However, in case b) there is a higher number of reignitions and the current is not interrupted in this phase, because after the last reignition, the current never meets the conditions imposed to the model.

The frequencies involved in the transients are very high, and it is known that the higher the frequencies, the

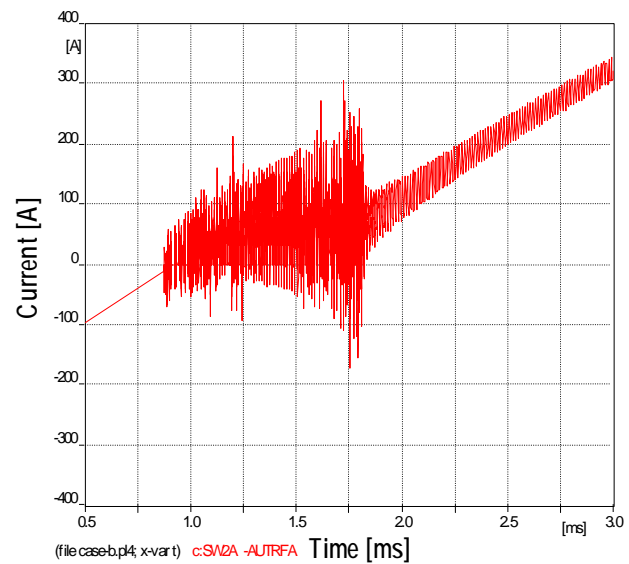
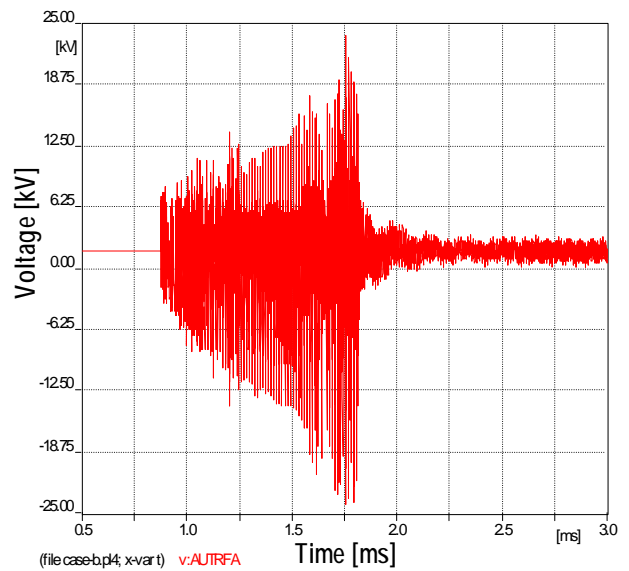

Fig. 5. a) Voltage at starting transformer, b) current through vacuum switch. Arc time = 0.25 ms

higher the proportion of the voltage that is applied to the first turns of the coil.

However, it is to be noted that this fast transients will depend on stray capacitances and inductances around the vacuum switch, that we do not know exactly and they have been estimated. The results are of the same quality as the input.

There are also other parameters that have influence on the phenomena in general, but we do not know and it is not possible to know, like the variation of the damping with the frequency. It is difficult in the model to get the correct damping for all the spread of frequencies involved.

It was considered more important to represent the damping for the highest frequencies than for the lowest, that's why it is observed a lack of damping in Figs. 4 and 5.

The values assumed in this study for some parameters, are based on previous experiences of measurement and simulation of fast transients [1], [2]. Reasonable variations

of these values were considered, without they are modified the obtained conclusions.

For transformers of 2.75 kV, the IEC 76 'Power Transformers' standard has specified a crest value of 60 kV for the impulse test, with a waveform of 1.2/50 μ s.

In the simulations, crest-to-crest values of 50 kV and time front close to one microsecond have been obtained. This is a severe stress to the inter-turn insulation of the coils and, what is worst, several of these impulses can occur in only one maneuver.

The opening of the starting current of the motor is not a frequent maneuver. In general it occurs by wrong operation of overcurrent protections, principally in the initial state of new installations, like this case.

VI. CONCLUSIONS

With the aid of some simplifications, it was possible to construct an acceptable digital model of the system.

The simulations made with this model show that, in case of reignitions of the arc, the voltage to ground at the starting transformer can be 25 kV, with frequencies of approximately one megahertz.

The crest-to-crest value can also be very high, up to 50 kV with the same frequency. The stress to the interturn insulation of the coils can be similar to those obtained in the impulse test.

This is a typical case when the high frequency voltages are not related with the lightning phenomena, and must be taken into account at the moment of specifying the equip-

ment tests, even in an industrial plant.

To obtain more precise results about the solicitations, it will be necessary more and better information about certain stray parameters. Field test will be necessary to allow us to obtain useful information about this subject.

However, with the obtained results it is useful to understand that, to the new transformer, it is mandatory to specify the impulse test of them.

VII. REFERENCES

- [1] R. Bianchi Lastra, J. Barbero and A. Rifaldi, *Comparison of Field Measurements with Simulations of Transients in an Arc Furnace*, Proceedings of 1997 European EMTP-ATP User Group Meeting, November 9-11, Barcelona, Spain
- [2] R. Bianchi Lastra, P. Arnera, D. Llaens, F Matzkevich, *Estudio de Transitorios Rápidos Producidos por la Maniobra de Interruptores de Vacío*, Proceedings of V Encuentro Regional Latinoamericano de la CIGRE (ERLAC), May 23-27, 1993, Ciudad del Este, Paraguay
- [3] M T. Glinkowski, P.G.Slade and R.P.P.Smeets, *IEEE Tutorial on the Vacuum Switchgear*. IEEE Publications TP-135-0, edited by
- [4] Pritindra Chowdhuri, *Electromagnetics Transients in Power Systems*, Research Studies Press, England, 1996.
- [5] Allan Greenwood, *Electrical Transients in Power Systems*, Wiley, New York, 1991